



# Marie Skłodowska-Curie Actions Postdoctoral Fellowship (PF)

Mariarita de Luca, Trieste 30.08.223

[mariarita.deluca@areasciencepart.it](mailto:mariarita.deluca@areasciencepart.it)

Institute for Research and Innovative Technologies (RIT) – AREA SCIENCE PARK

---

[research@sissa.it](mailto:research@sissa.it)

Research Office SISSA – Scuola Internazionale Superiore di Studi Avanzati

This work © 2023 by Mariarita de Luca is licensed under [CC BY 4.0](https://creativecommons.org/licenses/by/4.0/) 





# Who is Marie Curie?



Maria Skłodowska-Curie

Marie Curie or Maria Skłodowska (7 November 1867 – 4 July 1934) was a Polish physicist, chemist and mathematician who spent most of her life in France.

In 1903 she was the first woman to be awarded the Nobel Prize. She received the **Nobel Prize in Physics**, together with her husband Pierre Curie and Antoine Henri Becquerel, for her studies on radiation.

In 1911 she received the **Nobel Prize in Chemistry** for discovering radium and polonium, whose name was chosen in honor of his native land. She was one of five Nobel laureates to have received two and **she is the only one to have won the Prize in two distinct scientific fields.**

Marie Curie grew up in Russian Poland; **Since women could not be admitted to higher studies** here, then she moved to Paris and in 1891 began attending the Sorbonne, where she graduated in physics and mathematics.

In December 1897 she began to carry out studies on radioactive substances, which will remain the focus of her interests ever since.

In 1906, after the death of her husband Pierre Curie, she was allowed to teach at the Sorbonne.

Two years later she was appointed to the chair of general physics, **making her the first woman to teach at the Sorbonne.**

[Wikipedia](#)

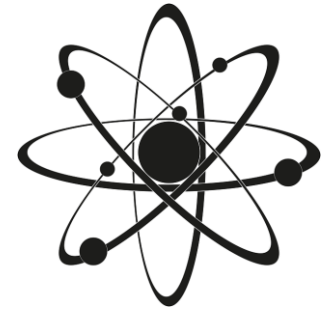

[Image by Chris Raz from Pixabay](#)

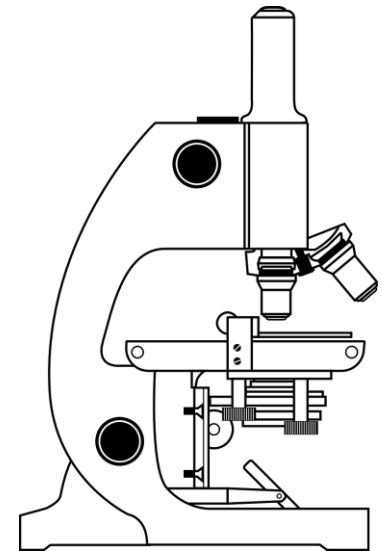

[Image by Clker-Free-Vector-Images from Pixabay](#)







# MSCA PF call : Expected Scope, Object and Impact

**Scope:** Fellowships will be provided to **excellent researchers undertaking international mobility**. Applications will be made jointly by the researcher and a beneficiary in the academic or non-academic sector.

**Object:** The goals of the work performed within the project, in terms of its research and innovation content. This will be translated into the **project's results**. These may range from tackling specific research questions, demonstrating the feasibility of an innovation, sharing knowledge among stakeholders on specific issues. The nature of the objectives will depend on the type of action, and the scope of the topic.

**Impact:** Wider **long term effects** on society (including the environment), the economy and science, enabled by the outcomes of R&I investments (long term). Impacts generally occur some time after the end of the project.

(See Template Part B in the following slides).





# Expected Outcome

**Definition of Outcome:** *The expected effects, over the medium term, of projects supported under a given topic. The results of a project should contribute to these outcomes, fostered in particular by the dissemination and exploitation measures. This may include the uptake, diffusion, deployment, and/or use of the project's results by direct target groups. Outcomes generally occur during or shortly after the end of the project.*

## For supported postdoctoral fellows:

- **Increased set of research and transferable skills and competences**, leading to improved employability and career prospects of MSCA postdoctoral fellows within academia and beyond;
- New mind-sets and approaches to R&I work forged through **international, inter-sectoral and interdisciplinary experience**;
- Enhanced networking and communication capacities with scientific peers, as well as with the **general public that will increase and broaden the research and innovation impact**.

## For participating organisations:

- Increased alignment of working conditions for researchers in accordance with the principles set out in the European Charter for Researchers and the Code of Conduct for the Recruitment of Researchers;
- Enhanced quality and sustainability of **research training and supervision**;
- Increased global attractiveness, **visibility and reputation of the participating organisation(s)**;
- Stronger R&I capacity and output among participating organisations; **better transfer of knowledge**;
- Regular feedback of **research results into teaching and education** at participating organisations.





# Eligibility conditions

## Project:

- **Bottom up** Approach for the research topic
- Proposals involving the same recruiting organisation (and for Global Postdoctoral Fellowships also the associated partner hosting the outgoing phase) and individual researcher submitted to the previous call of MSCA Postdoctoral Fellowships under Horizon Europe and having received a score of **less than 70% must not be resubmitted the following year.**
- Only **one proposal per individual** researcher can be submitted.

## Participating organisations:

- Applications must be submitted by a **single independent legal entity**, established in an **EU Member State or Horizon Europe Associated Country**. This is a mono-beneficiary action.
- The associated partner hosting the outgoing phase in Global Postdoctoral Fellowships must include a letter of commitment in the proposal to ensure their active participation in the action.
- Affiliated entities are not allowed to participate as they cannot claim costs in MSCA Postdoctoral Fellowships.



# Eligibility conditions

## Researcher:

- Supported fellows must be **postdoctoral researchers** at the date of the call deadline, i.e. in a possession of a doctoral degree.
- At the call deadline, supported researchers must have a **maximum of 8 years full-time equivalent experience in research**, measured from the date of award of the doctoral degree \*\*.
- Recruited researchers must comply with the following **mobility rule**:  
*they must not have resided or carried out their main activity (work, studies, etc.) in the country of the beneficiary (for European Postdoctoral Fellowships), or the host organisation for the outgoing phase (for Global Postdoctoral Fellowships) for more than 12 months in the 36 months immediately before the call deadline.*
- Supported researchers can be **of any nationality**.

**\*\*Maternity:** for each child born prior to the call deadline, 18 months will be deducted from the experience in research unless the applicant can document a longer parental leave prior to the call deadline.

**Paternity:** for each child born prior to the call deadline, the documented time of parental leave taken until the call deadline will be deducted from the experience in research.

# European (EF) and Global Fellowships (GF)



## European Postdoctoral Fellowship:

- Researcher can have any nationality and be from any country
- Host Institution must be a European Member State\*\* or [Associated Country](#)
- **12/24 months** duration
- **Mobility** rule apply to the HI country
- Secondment up to 1/3 of total fellowship in any country worldwide (single period or divided in shorter mobility periods).

## Placement in non-academic sector:

If requested and justified in the proposal, an **additional period of up to six months** at the end of the project can be awarded to researchers who will spend that period in a **non-academic organisation** established in an EU Member State or Horizon Europe Associated Country.

The request for such a non-academic placement must be an integral part of the proposal, explaining the added-value for the project and for the career development of the researcher, and will be subject to evaluation.

## Global Postdoctoral Fellowship

- Researcher must be long term resident of a European Member State\*\* or [Associated Country](#)
- Host Institution (ingoing phase) must be a European Member State\*\* or [Associated Country](#)
- **12 months** duration **ingoing** phase
- Associated Partner (outgoing phase) must be a [Third Country](#)
- **12/24 months** duration **outgoing** phase
- **Mobility** rule apply only to the country of the outgoing phase
- Secondment up to 1/3 of the outgoing phase.

\*\*EU Members States: Austria, Belgium, Bulgaria, Croatia, Republic of Cyprus, Czech Republic, Denmark, Estonia, Finland, France, Germany, Greece, Hungary, Ireland, Italy, Latvia, Lithuania, Luxembourg, Malta, Netherlands, Poland, Portugal, Romania, Slovakia, Slovenia, Spain and Sweden

Image by GraphicMama-team from Pixabay



# How to apply for a MSCA PF project with SISSA as Host Institution

- Contact a SISSA's professor to have his/her scientific support and his/her commitment to become your supervisor for a MSCA project.
- Contact the Research Office ([research@sissa.it](mailto:research@sissa.it)) to have all the information and the support you need.
- The Research Office will send you a «project form» to be filled with all the project details.
- Your project will be discussed in the Scientific Area's Council and eventually will be approved. The date of the Council must be before the MSCA call deadline, you cannot apply for the project without the formal approval.
- Be aware that you need to move **well in advance** before the deadline of the call.

# Funding and Tender Portal

Due to a technical maintenance, external users could experience issues accessing documents under formal notifications on Thursday 24/08/2023 from 17:00 to 17:30 CET. We apologize for any inconvenience this may cause.

Find calls for proposals and tenders

Horizon4Ukraine Brexit info Report fraud

Search calls for proposals and tenders by keywords, programmes... Search

- ### EU Programmes
- Asylum, Migration and Integration Fund (AMIF)
  - Border Management and Visa Policy Instrument (BMVI)
  - Customs Programme (CUST)
  - Digital Europe Program (DIGITAL)
  - Europe Direct (ED)
  - European Defence Fund (EDF)

## Create an account

[Help for external users](#)

**First name**

**Last name**

**E-mail**

**Confirm e-mail**

**E-mail language**

English (en) ▼

By checking this box, you acknowledge that you have read and understood the [privacy statement](#)

**Create an account** Cancel

### News

Aug 22, 2023  
**RENEWFM: Final Q&A Session before call closure**  
On 5 September 2023 the RENEWFM Programme team at CINEA will organise a final Q&A session before call closure, in order to clarify any pending questions. The de...

Aug 22, 2023  
**EC Horizon Results Platform & EU IP Helpdesk "IP Assessment" webinar**  
This webinar is part of a series, organized in co-operation with the EU IP Helpdesk, as an introduction to the main aspects of IP management, notably: &n...

Jul 24, 2023  
**Short video tutorial on lump sums in Horizon Europe**  
The Commission has just released two short videos to explain how lump sums work in Horizon Europe. The videos were created to brief experts who evaluate lump su...

All news >

### Events

**Horizon Implementation Day: Grant Management in Horizon Europe**  
24 Oct 2023 09:30

**Lump Sum Funding in Horizon Europe: How does it work? How to write a**





# Call: MSCA Postdoctoral Fellowship 2023

## General information

Programme

**Horizon Europe Framework Programme (HORIZON)**

Call

**[MSCA Postdoctoral Fellowships 2023 \(HORIZON-MSCA-2023-PF-01\)](#)**

Type of action

**HORIZON-TMA-MSCA-PF-EF HORIZON TMA MSCA Postdoctoral Fellowships - European Fellowships**

**HORIZON-TMA-MSCA-PF-GF HORIZON TMA MSCA Postdoctoral Fellowships - Global Fellowships**

Deadline model

**single-stage**

Opening date

**12 April 2023**

To access the Electronic Submission Service, please click on the submission-button next to the **type of action** and the **type of model grant agreement** that corresponds to your proposal. You will then be asked to confirm your choice, as it cannot be changed in the submission system. Upon confirmation, you will be linked to the correct entry point.

To access existing draft proposals for this topic, please login to the Funding & Tenders Portal and select the My Proposals page of the My Area section.

Please select the type of your submission:

- HORIZON TMA MSCA Postdoctoral Fellowships - European Fellowships [HORIZON-TMA-MSCA-PF-EF], HORIZON Unit Grant [HORIZON-AG-UN]
- HORIZON TMA MSCA Postdoctoral Fellowships - Global Fellowships [HORIZON-TMA-MSCA-PF-GF], HORIZON Unit Grant [HORIZON-AG-UN]

[Start submission](#)

Type of MGA

**HORIZON Unit Grant [HORIZON-AG-UN]**

**HORIZON Unit Grant [HORIZON-AG-UN]**

Deadline date

**13 September 2023 17:00:00 Brussels time**



\* The European Institute of Innovation & Technology (EIT) is not part of the Specific Programme



# Proposal Page

## Proposal forms

**Deadline**  
13 September 2023 17:00:00 Brussels Local Time

days left until closure

**Call data**

Call: HORIZON-MSCA-2023-PF-01  
Topic: HORIZON-MSCA-2023-PF-01-01  
Type of action: HORIZON-TMA-MSCA-PF-EF  
Type of MGA: HORIZON-AG-UN

⚠️ Topic and type of action can only be changed by creating a new proposal.

**Proposal data**

Acronym:  
Draft ID:

**Download Part B templates**

Download part B templates

**i** In this step you can edit the Administrative Forms and upload the proposal and its annexes. You may return to this step from the 'My Proposals' section of the Funding & Tenders Portal.

Submit your proposal as early in the process as possible - you can update and resubmit an improved version many times before the call closure.

Submitting a proposal will overwrite any previous versions of this same proposal - this process is irreversible.

Any changes made to the proposal will not be available to the European Commission service unless resubmitted before the call closure.

**x** Your proposal contains changes that have not yet been submitted.

**Administrative forms (Part A)**

[Edit forms](#) [View history](#) [Print preview](#)

**Part B and Annexes**

In this section you may upload the technical annex of the proposal (in PDF format only) and any other requested attachments.

Part B1 \*  [Upload](#)

Part B2 \*  [Upload](#)

[← BACK TO PARTICIPANTS LIST](#) [VALIDATE](#) [SUBMIT](#)



# Beneficiary and Other partners



**Applicant (FUTURE BENEFICIARY)**  
SISSA

1 SISSA

SCUOLA INTERNAZIONALE SUPERIORE DI STUDI AVANZATI DI TRIESTE  
TRIESTE, IT  
PIC: 999850878

**Contacts** 3 [Add contact +](#)

**Researcher** [edit] [delete] [dropdown]

**Supervisor (Main contact person)** [edit] [delete] [dropdown]

**Contact person** [edit] [dropdown]

[Change organisation](#) [Contact organisation](#)

[Add Partner +](#)

[Add Associated partner +](#)

- Participating organization(s):
- Beneficiary (compulsory)
  - Associated partner linked to a beneficiary (if applicable)
  - Associated partner for outgoing phase (compulsory for GF only)
  - Associated partner for secondment (optional)
  - Associated partner for non-academic placement (optional)





# Template Instructions - Part A - Online

< Exit form

Table of contents

General Information >

Table of contents    Validate form    Save form    Save & exit form

## Table of contents

Section	Title	Action
1	General information	<a href="#">Show</a>
2	Participants	<a href="#">Show</a>
3	Budget	<a href="#">Show</a>
4	Ethics and security	<a href="#">Show</a>
5	Other questions	<a href="#">Show</a>







# Template Instructions - Part A - Online

Abstract \*



## Application forms

Proposal ID

Acronym

Has this proposal (or a very similar one) been submitted in the past 2 years in response to a call for proposals under any EU programme, including the current call?

Yes  No



Please give the proposal reference or contract number.

Add

*Previously submitted proposals should be with either 6 or 9 digits.*

Remove

[FAQs about resubmissions](#)









# Template Instructions - Part A - Online

## Declarations



Field(s) marked \* are mandatory to fill.

- 1) We declare to have the explicit consent of all applicants on their participation and on the content of this proposal. \* 
- 2) We confirm that the information contained in this proposal is correct and complete and that none of the project activities have started before the proposal was submitted (unless explicitly authorised in the call conditions). \* 
- 3) We declare:
  - to be fully compliant with the eligibility criteria set out in the call 
  - not to be subject to any exclusion grounds under the [EU Financial Regulation 2018/1046](#)
  - to have the financial and operational capacity to carry out the proposed project. \*
- 4) We acknowledge that all communication will be made through the Funding & Tenders Portal electronic exchange system and that access and use of this system is subject to the [Funding & Tenders Portal Terms and Conditions](#). \* 
- 5) We have read, understood and accepted the [Funding & Tenders Portal Terms & Conditions](#) and [Privacy Statement](#) that set out the conditions of use of the Portal and the scope, purposes, retention periods, etc. for the processing of personal data of all data subjects whose data we communicate for the purpose of the application, evaluation, award and subsequent management of our grant, prizes and contracts (including financial transactions and audits). \* 





# Template Instructions - Part A - Online

6) We declare that the proposal complies with ethical principles (including the highest standards of research integrity as set out in the [ALLEA European Code of Conduct for Research Integrity](#), as well as applicable international and national law, including the Charter of Fundamental Rights of the European Union and the European Convention on Human Rights and its Supplementary Protocols. [Appropriate procedures, policies and structures](#) are in place to foster responsible research practices, to prevent questionable research practices and research misconduct, and to handle allegations of breaches of the principles and standards in the Code of Conduct. \*



7) We declare that the proposal has an exclusive focus on civil applications (activities intended to be used in military application or aiming to serve military purposes cannot be funded). If the project involves dual-use items in the sense of [Regulation 2021/821](#), or other items for which authorisation is required, we confirm that we will comply with the applicable regulatory framework (e.g. obtain export/import licences before these items are used). \*



8) We confirm that the activities proposed do not

- aim at human cloning for reproductive purposes;
- intend to modify the genetic heritage of human beings which could make such changes heritable (with the exception of research relating to cancer treatment of the gonads, which may be financed), or
- intend to create human embryos solely for the purpose of research or for the purpose of stem cell procurement, including by means of somatic cell nuclear transfer.
- lead to the destruction of human embryos (for example, for obtaining stem cells)



These activities are excluded from funding. \*

9) We confirm that for activities carried out outside the Union, the same activities would have been allowed in at least one EU Member State. \*



The coordinator is only responsible for the information relating to their own organisation. Each applicant remains responsible for the information declared for their organisation. If the proposal is retained for EU funding, they will all be required to sign a declaration of honour.

**False statements** or incorrect information may lead to administrative sanctions under the EU Financial Regulation.





# Template Instructions - Part A - Online

< Exit form

Table of contents

General Information >

Table of contents    Validate form    Save form    Save & exit form

## Table of contents

Section	Title	Action
1	General information	Show
2	Participants	Show
3	Budget	Show
4	Ethics and security	Show
5	Other questions	Show





# Template Instructions - Part A - Online

## 2 - Participants

### List of participating organisations

#	Participating Organisation Legal Name	Country	Role	Action
1	SCUOLA INTERNAZIONALE SUPERIORE DI STUDI A	Italy	Coordinator	<a href="#">Show Participant's Details</a>

### Application forms

Proposal ID

Acronym

Short name **SISSA**

Departments carrying out the proposed work

Add a Department

?

#### Department 1

Department name *Name of the department/institute carrying out the work.*  not applicable

Same as proposing organisation's address

Street *Please enter street name and number.*

Town *Please enter the name of the town.*

Postcode *Area code.*

Country *Please select a country*



# Template Instructions - Part A - Online

## Supervisor

This will be the person the EU services will contact concerning this proposal (e.g. for additional information, invitation to hearings, sending of evaluation results, convocation to start grant preparation). The data in blue is read-only. Details (name, first name and e-mail) of Main Contact persons should be edited in the step "Participants" of the submission wizard.

Title  Gender  Woman  Man  Non Binary

First name\*  Last name\*

E-Mail\*

Position in org. *Please indicate the position of the person.*

Department *Name of the department/institute carrying out the work.*   Same as organisation name

Same as proposing organisation's address

Street *Please enter street name and number.*

Town *Please enter the name of the town.*  Post code *Area code.*

Country *Please select a country*

Website *Please enter website*

Phone *+xxx xxxxxxxxx*  Phone 2 *+xxx xxxxxxxxx*

## Other contact persons



First Name	Last Name	E-mail	Phone
			+xxx xxxxxxxxx



# Template Instructions - Part A - Online

## Researcher

The name and e-mail of the Researcher and Supervisor are read-only in the administrative form, only additional details can be edited here. To give access rights and contact details of contact persons, please go back to Participants page of the submission wizard and save the changes.

Last Name*	<input type="text"/>	Last Name at Birth	<input type="text"/>
First Name(s)*	<input type="text"/>	Gender*	<input type="radio"/> Woman <input type="radio"/> Man <input type="radio"/> Non binary
Title	<input type="text"/>	Country of residence*	<input type="text"/>
Nationality*	<input type="text"/>	Nationality 2	<input type="text"/>
Date of Birth (DD/MM/YYYY)	<input type="text"/>	Country of Birth*	<input type="text"/>
		Place of Birth	<input type="text"/>

### Place of activity/place of residence (previous 5 years - most recent one first)

Indicate the period(s) and the country/countries in which you have legally resided and/or had your main activity (work, studies, etc) during the last 5 years up until the deadline for the submission of the proposal.  
Please fill in this section without gaps

Period from	Period to	Duration (days)	Country	Add
			<input type="text"/>	<input type="button" value="Add"/>
		Total		



# Template Instructions - Part A - Online

## Contact address

Current organisation name

Current Department/Faculty/Institute/  
Laboratory name

Same as organisation address

Street

*Please enter street name and number.*

Postcode/Cedex

Town

Phone

+xxx xxxxxxxx

Country

Phone2 / Mobile

+xxx xxxxxxxx

E-Mail\*

ORCID

If you have a ORCID number please enter it here (e.g. 9999-9999-9999-999X, where 9 represents numbers and X represents numbers up to 10)

Researcher ID

*The maximum length of the identifier is 11 characters (ZZZ-9999-2010) and the minimum length is 9 characters (A-1001-2010).*

Other ID

Please enter the type of ID here

Please enter the identifier number here

## Qualifications

Doctorate Date of (expected) award

Select the exact date(DD/  
MM/YYYY)









# Template Instructions - Part A - Online

< Exit form

Table of contents

General Information >

Table of contents    Validate form    Save form    Save & exit form

## Table of contents

Section	Title	Action
1	General information	<a href="#">Show</a>
2	Participants	<a href="#">Show</a>
3	Budget	<a href="#">Show</a>
4	Ethics and security	<a href="#">Show</a>
5	Other questions	<a href="#">Show</a>





# Template Instructions - Part A - Online

## 3 - Budget

Is the Researcher eligible for family allowance?\*

Yes  No

Duration of fellowship *	Country in which fellowship will take place
	▼ Italy ▼

	Country Coefficient	Number of Months	Contributions for recruited researchers			Institutional contributions		Total
			Living Allowance	Mobility Allowance	Family Allowance	Research, training and networking costs	Management and indirect costs	
Fellowship	0.974	0	0.00	0.00	0.00	0.00	0.00	0.00
Total			0.00	0.00	0.00	0.00	0.00	0.00

If the postdoctoral researcher has or acquires family obligations during the action duration, i.e. has persons linked to him/her by (i) marriage, or (ii) a relationship with equivalent status to a marriage recognised by the legislation of the country or region where this relationship was formalised; or (iii) dependent children who are actually being maintained by the researcher, the family allowance must be paid to him/her as well.

By filling the duration of the fellowship the budget is automatically filled, once you have defined the Country. Please note that in the case of the Global fellowship, you will have two Countries to choose (for the outgoing and the ingoing phases) and the duration of both phases to declare.

MSCA PF general Contributions

MSCA Postdoctoral Fellowships	Contributions for the recruited researcher per person-month					Institutional unit contributions per person-month	
	Living allowance	Mobility allowance	Family allowance (if applicable)	Long-term leave allowance (if applicable)	Special needs allowance (if applicable)	Research, training and networking contribution	Management and indirect contribution
	EUR 5 080	EUR 600	EUR 660	EUR 5 680 x % covered by the beneficiary	requested unit <sup>93</sup> x (1/number of months)	EUR 1 000	EUR 650



# Template Instructions - Part A - Online

< Exit form

Table of contents

General Information >

Table of contents    Validate form    Save form    Save & exit form

## Table of contents

Section	Title	Action
1	General information	Show
2	Participants	Show
3	Budget	Show
4	Ethics and security	Show
5	Other questions	Show





# Template Instructions - Part A - Online

## 4 - Ethics & security

### Ethics Issues Table



1. Human Embryonic Stem Cells and Human Embryos		Page
Does this activity involve Human Embryonic Stem Cells (hESCs)?	<input type="radio"/> Yes <input checked="" type="radio"/> No	
Does this activity involve the use of human embryos?	<input type="radio"/> Yes <input checked="" type="radio"/> No	
2. Humans		Page
Does this activity involve human participants?	<input type="radio"/> Yes <input checked="" type="radio"/> No	
Does this activity involve interventions (physical also including imaging technology, behavioural treatments, etc.) on the study participants?	<input type="radio"/> Yes <input checked="" type="radio"/> No	
Does this activity involve conducting a clinical study as defined by the Clinical Trial <a href="#">Regulation (EU 536/2014)</a> ? (using pharmaceuticals, biologicals, radiopharmaceuticals, or advanced therapy medicinal products)	<input type="radio"/> Yes <input checked="" type="radio"/> No	
3. Human Cells / Tissues (not covered by section 1)		Page
Does this activity involve the use of human cells or tissues?	<input type="radio"/> Yes <input checked="" type="radio"/> No	
4. Personal Data		Page
Does this activity involve processing of personal data?	<input type="radio"/> Yes <input checked="" type="radio"/> No	
Does this activity involve further processing of previously collected personal data (including use of preexisting data sets or sources, merging existing data sets)?	<input type="radio"/> Yes <input checked="" type="radio"/> No	
Is it planned to export personal data from the EU to non-EU countries?	<input type="radio"/> Yes <input checked="" type="radio"/> No	
Is it planned to import personal data from non-EU countries into the EU or from a non-EU country to another non-EU country?	<input type="radio"/> Yes <input checked="" type="radio"/> No	
Does this activity involve the processing of personal data related to criminal convictions or offences?	<input type="radio"/> Yes <input checked="" type="radio"/> No	



# Template Instructions - Part A - Online

5. Animals	Page
Does this activity involve animals?	<input type="radio"/> Yes <input checked="" type="radio"/> No
6. Non-EU Countries	Page
Will some of the activities be carried out in non-EU countries?	<input type="radio"/> Yes <input checked="" type="radio"/> No
In case non-EU countries are involved, do the activities undertaken in these countries raise potential ethics issues?	<input type="radio"/> Yes <input checked="" type="radio"/> No
It is planned to use local resources (e.g. animal and/or human tissue samples, genetic material, live animals, human remains, materials of historical value, endangered fauna or flora samples, etc.)?	<input type="radio"/> Yes <input checked="" type="radio"/> No
Is it planned to import any material (other than data) from non-EU countries into the EU or from a non-EU country to another non-EU country? For data imports, see section 4.	<input type="radio"/> Yes <input checked="" type="radio"/> No
Is it planned to export any material (other than data) from the EU to non-EU countries? For data exports, see section 4.	<input type="radio"/> Yes <input checked="" type="radio"/> No
Does this activity involve <a href="#">low and/or lower middle income countries</a> , (if yes, detail the benefit-sharing actions planned in the self-assessment)	<input type="radio"/> Yes <input checked="" type="radio"/> No
Could the situation in the country put the individuals taking part in the activity at risk?	<input type="radio"/> Yes <input checked="" type="radio"/> No





# Template Instructions - Part A - Online

7. Environment, Health and Safety	Page
Does this activity involve the use of substances or processes that may cause harm to the environment, to animals or plants.(during the implementation of the activity or further to the use of the results, as a possible impact) ?	<input type="radio"/> Yes <input checked="" type="radio"/> No
Does this activity deal with endangered fauna and/or flora / protected areas?	<input type="radio"/> Yes <input checked="" type="radio"/> No
Does this activity involve the use of substances or processes that may cause harm to humans, including those performing the activity.(during the implementation of the activity or further to the use of the results, as a possible impact) ?	<input type="radio"/> Yes <input checked="" type="radio"/> No
8. Artificial Intelligence	Page
Does this activity involve the development, deployment and/or use of Artificial Intelligence-based systems?	<input type="radio"/> Yes <input checked="" type="radio"/> No
9. Other Ethics Issues	Page
Are there any other ethics issues that should be taken into consideration?	<input type="radio"/> Yes <input checked="" type="radio"/> No

I confirm that I have taken into account all ethics issues above and that, if any ethics issues apply, I will complete the ethics self-assessment as described in the guidelines [How to Complete your Ethics Self-Assessment](#)



**If you replied yes** to one of the questions, you need to specify in the grey box in which proposal page the ethics aspect is mentioned.

**In the following self assessment boxes, you must explain the ethics aspects faced by your project and how you are going to approach them and eventually solve them.**



# Template Instructions - Part A - Online

## Ethics Self-Assessment



### Ethical dimension of the objectives, methodology and likely impact

Explain in detail the identified issues in relation to:

- objectives of the activities (e.g. study of vulnerable populations, etc.)
- methodology (e.g. clinical trials, involvement of children, protection of personal data, etc.)
- the potential impact of the activities (e.g. environmental damage, stigmatisation of particular social groups, political or financial adverse consequences, misuse, etc.)

**In the case of no ethics issues, please declare that:**

*The described project is not subjected to ethical issues*

Remaining characters

5000

### Compliance with ethical principles and relevant legislations

Describe how the issue(s) identified in the ethics issues table above will be addressed in order to adhere to the ethical principles and what will be done to ensure that the activities are compliant with the EU/national legal and ethical requirements of the country or countries where the tasks are to be carried out. It is reminded that for activities performed in a non-EU countries, they should also be allowed in at least one EU Member State.

**(Always) Proposal complies with ethical principles and the applicable international, EU and national law.**

**(If applicable) For project concerning personal data, please specify:**

*In compliance with the rules and regulations regarding personal data, the beneficiary confirms that it will comply with the European Regulation 2016/679 (General Data Protection Regulation).*

Remaining characters

5000





# Template Instructions - Part A - Online

[< Exit form](#)

[Table of contents](#)

[General Information >](#)

Table of contents    Validate form    Save form    Save & exit form

## Table of contents

Section	Title	Action
1	General information	<a href="#">Show</a>
2	Participants	<a href="#">Show</a>
3	Budget	<a href="#">Show</a>
4	Ethics and security	<a href="#">Show</a>
5	Other questions	<a href="#">Show</a>





# Template Instructions - Part A - Online

## 5 - Other questions

### Information on the Researcher (future fellow)

1. Were you in the last 3 years in compulsory national service?  Yes  No

2. Did you spend time, in the last 3 years, on procedures for obtaining refugee status (according to the 1951 Geneva Refugee Convention and the 1967 Protocol) in a Member State or Associated Country to Horizon Europe?  Yes  No

3. Are you a national of a Member State or Associated Country?  Yes  No

Country







# Template Instructions - Part B

- Part B of the proposal contains the details of the proposed MSCA Postdoctoral Fellowship as well as the required supporting information.
- It will be used by the independent experts to undertake their assessment of the proposal.
- Applicants must address each of the award criteria as outlined in the relevant sections, using both descriptive text and the tables provided.
- Applicants must structure their MSCA-2023-PF proposal according to the headings indicated in the Part B proposal template.
- Please note that this call will be a **single-stage proposal** submission and evaluation procedure.
- Applicants must ensure that their proposals conform to this layout and to the instructions given.

**Please be aware that proposals will be evaluated as they were submitted, rather than on their potential if certain changes were to be made.**

**This means that only proposals that successfully address all the required aspects will have a chance of being funded.**



**SISSA**







# Template Instructions - Part B1

## Award criteria

- Proposals will be evaluated by experts on the basis of the award criteria '**excellence**', '**impact**' and '**quality and efficiency of the implementation**'.
- Evaluation scores will be awarded for each of these criteria, and not for the different aspects listed in the table beside. **Each criterion will be scored out of 5.**
- Proposals scoring equal to or above 70% will be considered for funding — within the limits of the available call budget. Other proposals will be rejected.

Excellence	Impact	Quality and efficiency of the implementation
Quality and pertinence of the project's research and innovation objectives (and the extent to which they are ambitious, and go beyond the state of the art)	Credibility of the measures to enhance the career perspectives and employability of the researcher and contribution to his/her skills development	Quality and effectiveness of the work plan, assessment of risks and appropriateness of the effort assigned to work packages
Soundness of the proposed methodology (including interdisciplinary approaches, consideration of the gender dimension and other diversity aspects if relevant for the research project, and the quality of open science practices)	Suitability and quality of the measures to maximise expected outcomes and impacts, as set out in the dissemination and exploitation plan, including communication activities	Quality and capacity of the host institutions and participating organisations, including hosting arrangements
Quality of the supervision, training and of the two-way transfer of knowledge between the researcher and the host	The magnitude and importance of the project's contribution to the expected scientific, societal and economic impacts	
Quality and appropriateness of the researcher's professional experience, competences and skills		
50%	30%	20%
<b>Weighting</b>		





# Template Instructions - Part B1

## Excellence – Methodology (Interdisciplinary and Transversal aspects)

- **Integration of methods and disciplines to pursue the objectives:** Explain how expertise and methods from different disciplines will be brought together and integrated in pursuit of your objectives. If you consider that an inter-disciplinary approach is unnecessary in the context of the proposed work, please provide a justification.
  - **Gender dimension and other diversity aspects:** Describe how the gender dimension and other diversity aspects are taken into account in the project's research and innovation content. If you do not consider such a gender dimension to be relevant in your project, please provide a justification.
  - **Open science practices:** Describe how appropriate open science practices are implemented as an integral part of the proposed methodology. Show how the choice of practices and their implementation is adapted to the nature of your work in a way that will increase the chances of the project delivering on its objectives [e.g. up to 1/2 page, including research data management]. If you believe that none of these practices are appropriate for your project, please provide a justification here.
- 
- **Research data management and management of other research outputs:** Applicants generating/collecting data and/or other research outputs (except for publications) during the project must explain how the data will be managed in line with the FAIR principles (Findable, Accessible, Interoperable, Reusable).



**SISSA**









# Template Instructions - Part B1



## Mandatory Open Science practices

(from [Annotated Model Grant Agreement](#)) in HE:

- open access to scientific publications: Beneficiaries (or authors) must retain sufficient intellectual property rights to comply with the open access requirements.
- Metadata of deposited publications must be open under a Creative Common Public Domain Dedication (**CC 0**) or equivalent, in line with the **FAIR principles** (in particular machine-actionable) and provide information at least about the following: *publication* (author(s), title, date of publication, publication venue); *Horizon Europe or Euratom funding*; *grant project name, acronym and number*; *licensing terms*; *persistent identifiers for the publication, the authors involved in the action*,...
- Where applicable, the metadata must include persistent identifiers for any research output or any other tools and instruments needed to validate the conclusions of the publication.
- Only publication fees in full open access venues for peer-reviewed scientific publications are eligible for reimbursement.







# Useful tools

## Search Sherpa Services

Helping authors and institutions make informed and confident decisions in open access publication and compliance.

Search all

Published Version

OA Publishing	This option includes Open Access publishing
Embargo	No embargo
Licence	CC BY v4.0
Copyright Owner	Authors
Locations	Any Website Named Repository (arXiv) Journal Website
Conditions	Published source must be acknowledged with citation

# Journal of High Energy Physics

**Title** Journal of High Energy Physics (JHEP) [English]  
**ISSN** 1126-6708  
**eISSN** 1029-8479  
**Publisher** [Springer](#)   
[Scuola Internazionale Superiore di Studi Avanzati \(SISSA\)](#)   
**Publisher URL** <https://www.springer.com/journal/13130>   
**DOAJ** <https://doaj.org/toc/1029-8479>









# Template Instructions - Part B1

## Examples of Open Science description:

“Open science practices will be employed at all phases of the project. For an open and early sharing of research, and to increase the transparency of the whole research process, we will preregister the planned studies (e.g. Open Science Framework platform) . We will publish the results as pre-prints (e.g. ArXiv) and as articles preferably in OA journals listed in the DOAJ and open-peer-review platform as ORE (Open Research Europe).

We will provide an open access to research outputs (code, metadata, group data, publications) through dedicated repositories, CC-BY 4.0 license (e.g. GitHub).

Research data management: All data will be collected according to standardized methods in my specific scientific field and monitored for quality during data collection.

All protocols will be approved by a local ethics committee. Informed consent forms will be signed prior to experiment (including data sharing information). All personal and sensitive data will be anonymized and coded. In compliance with the rules and regulations regarding personal data, the beneficiary confirms that it will comply with the European Regulation 2016/679 (General Data Protection Regulation). Research data will be managed according to the FAIR principles: Findability, Accessibility, Interoperability, Re-usability - “as open as possible, as closed as necessary”. We will use DOIs of our publications and available data, preferred file formats for long-term data preservation. A Data Management Plan including all described practices for the whole project team will be delivered at month 6° of the project and regularly updated.”



# Evaluation form

## Evaluation of Marie Skłodowska-Curie Actions (MSCA) in Horizon Europe

### REA – European Research Executive Agency



Figure 1: Overview of the evaluation process in MSCA. This process is fully in line with [the Horizon Europe evaluation process](#) presented on the [EC Funding and Tender Portal](#)



# Useful links

## Postdoctoral Fellowships – call 2023

For detailed information about the Postdoctoral Fellowships, including the eligibility conditions and implementation modalities, please check the corresponding sections in the [MSCA Work ProgrammeEN●●●](#) and the [dedicated Funding & Tenders portal page](#).

Additional useful information for applicants on the Postdoctoral Fellowships can be found in the:

- [Postdoctoral Fellowships Guide for Applicants 2023EN●●●](#)
- [General annexes of the Work programmeEN●●●](#)
- [Proposal template and instructions on how to fill it inEN●●●](#)
- [Common mistakes in MSCA-PF proposal submissionEN●●●](#)
- [MSCA specific evaluation forms used by the expert evaluatorsEN●●●](#)
- [Specific FAQs for Postdoctoral Fellowships call for proposals 2023](#)
- [Guidelines on the calculation of 8-years research experience in Postdoctoral Fellowships under Horizon EuropeEN●●●](#)
- [Postdoctoral Fellowships Self-assessment tool for the calculation of the 8-years research experienceEN●●●](#)
- [6 steps to prepare your application](#)

In order to help the REA select the appropriate expert evaluators whose expertise best matches your proposal, you will be asked to select [specific keywords](#) in the proposal template.

Any additional useful documents can be found on the [call page](#).



